

CA101339

MODEL 1148C

148 x 90 x 68

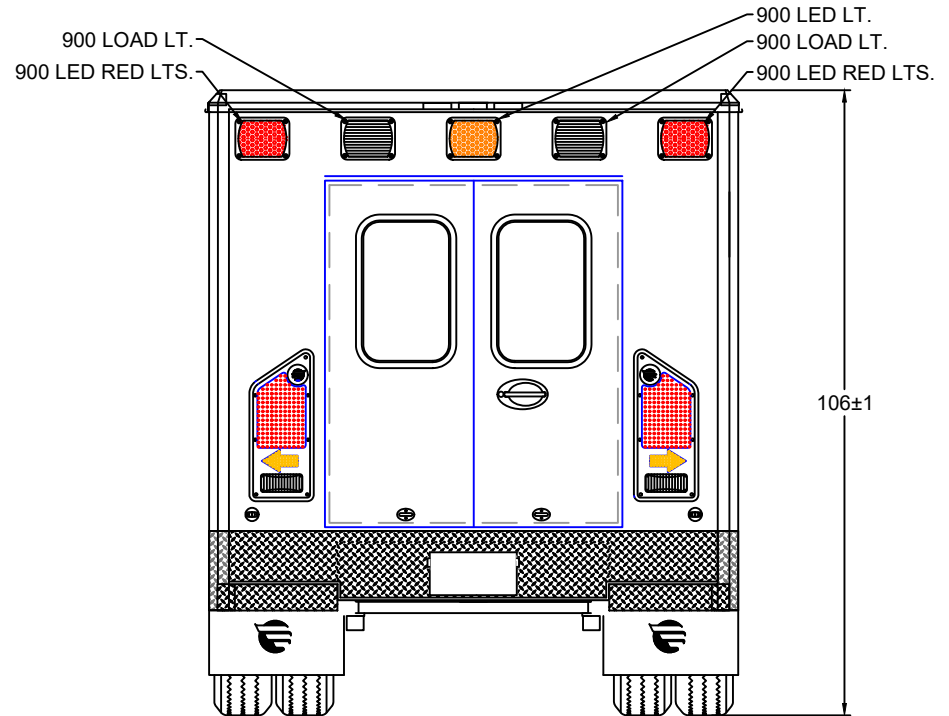
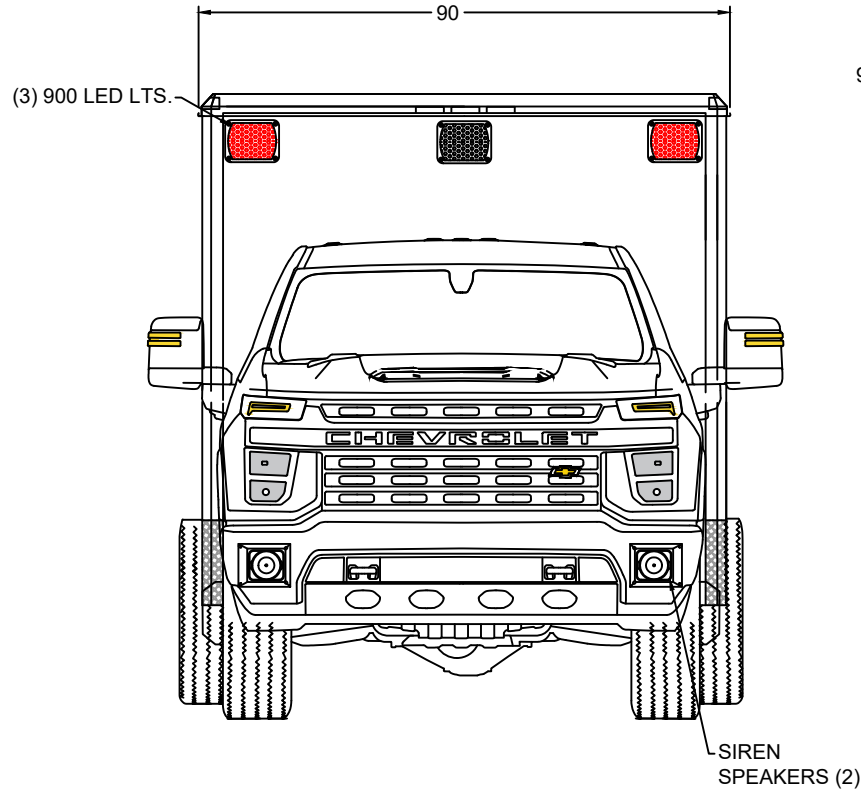

EXTERIOR COMPARTMENT DIMENSIONS IN INCHES

INTERIOR DIMENSIONS				PASS THRU		INTERIOR DIMENSIONS				JAMB OPENING	
COMPT.	HEIGHT	WIDTH	DEPTH	HEIGHT	WIDTH	COMPT.	HEIGHT	WIDTH	DEPTH	HEIGHT	WIDTH



TYPE 1 CHEVY  
FRONT / REAR  
EXTERIOR VIEWS

BE ADVISED THAT THESE ARE PRELIMINARY LAYOUTS INTENDED TO ILLUSTRATE DESIGN INTENT AND DIMENSIONS ARE FOR REFERENCE ONLY PRIOR TO FINAL ENGINEERING

DATE: 2/10/21

SCALE

DWN BY AP

DWG NO 1 / 11

49" AISLE

CA101339

MODEL 1148C

148 x 90 x 68

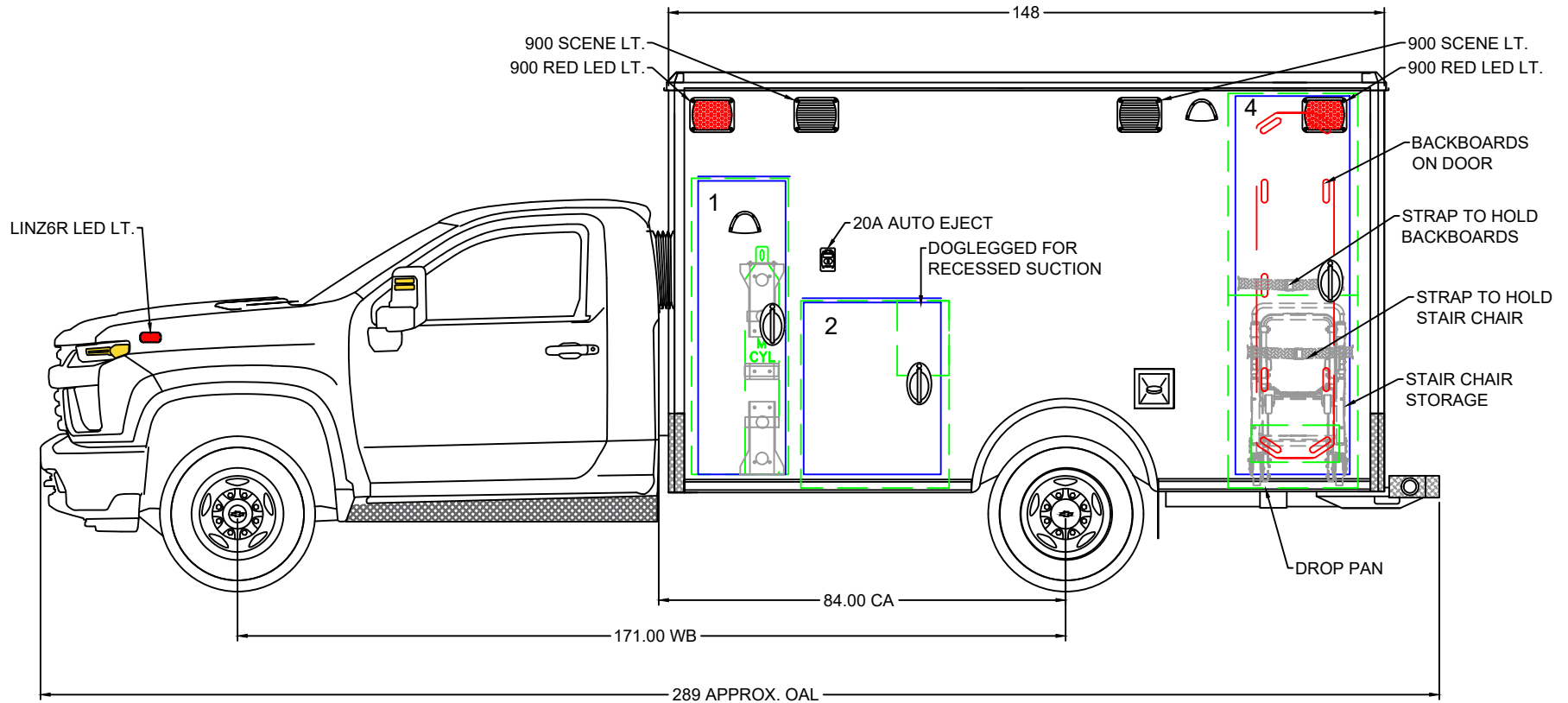

BE ADVISED THAT THESE ARE PRELIMINARY LAYOUTS INTENDED TO ILLUSTRATE DESIGN INTENT AND DIMENSIONS ARE FOR REFERENCE ONLY PRIOR TO FINAL ENGINEERING

EXTERIOR COMPARTMENT DIMENSIONS IN INCHES												
INTERIOR DIMENSIONS				JAMB OPENING		INTERIOR DIMENSIONS				JAMB OPENING		
COMPT.	HEIGHT	WIDTH	DEPTH	HEIGHT	WIDTH	COMPT.	HEIGHT	WIDTH	DEPTH	HEIGHT	WIDTH	
1	61.00	20.00	15.00	60.50	18.00							
2	38.75	30.50	15.00	35.75	28.25							
4	82.50	26.75	8.00	77.75	23.50							
49" AISLE												<small>DATE</small> 2/10/21 <small>SCALE</small> <small>DRAWN BY</small> AP <small>DWG NO</small> 2 / 11

CA101339

MODEL 1148C

148 x 90 x 68

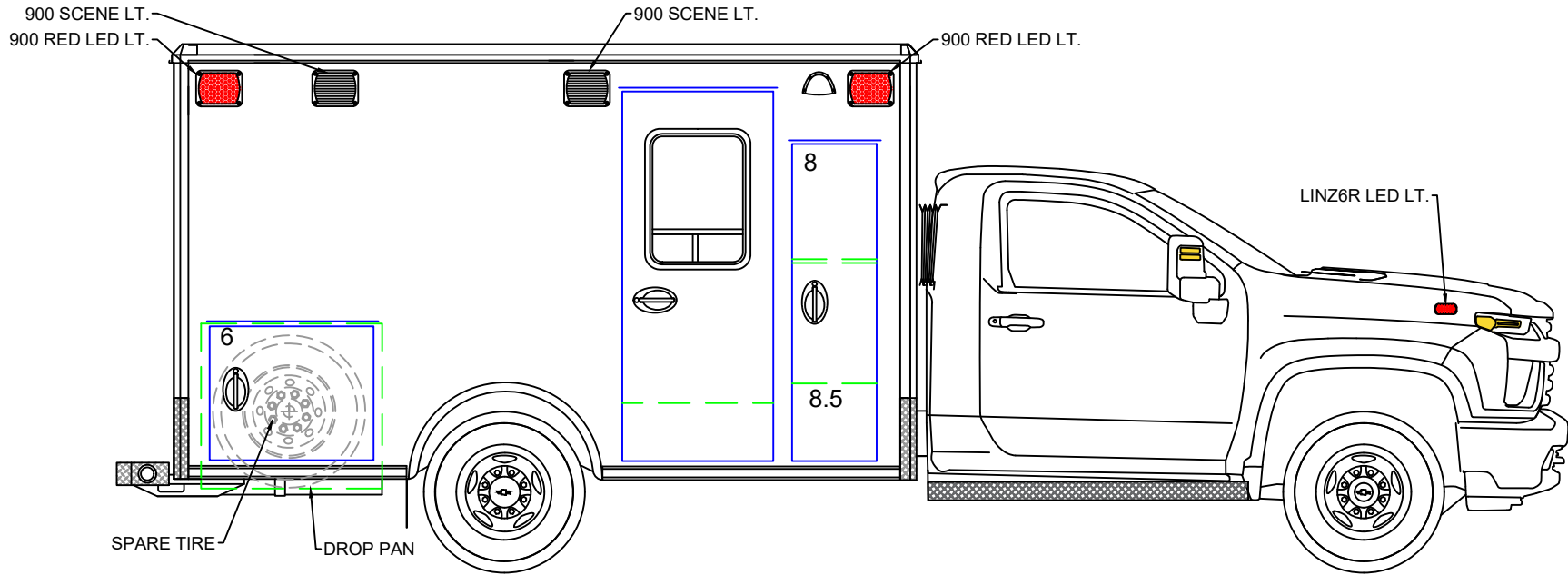

BE ADVISED THAT THESE ARE PRELIMINARY LAYOUTS INTENDED TO ILLUSTRATE DESIGN INTENT AND DIMENSIONS ARE FOR REFERENCE ONLY PRIOR TO FINAL ENGINEERING

EXTERIOR COMPARTMENT DIMENSIONS IN INCHES													
INTERIOR DIMENSIONS				JAMB OPENING		INTERIOR DIMENSIONS				JAMB OPENING			
COMPT.	HEIGHT	WIDTH	DEPTH	HEIGHT	WIDTH	COMPT.	HEIGHT	WIDTH	DEPTH	HEIGHT	WIDTH	DATE	SCALE
8				61.75	16.75							2/10/21	
8.5	15.50	19.00	18.75									DRAWN BY	DWG NO
6	32.75	38.00	15.50	26.75	34.50							AP	3 / 11
49" AISLE													

TYPE 1 CHEVY  
RIGHT EXT. VIEW

CA101339

MODEL 1148C

148 x 90 x 68

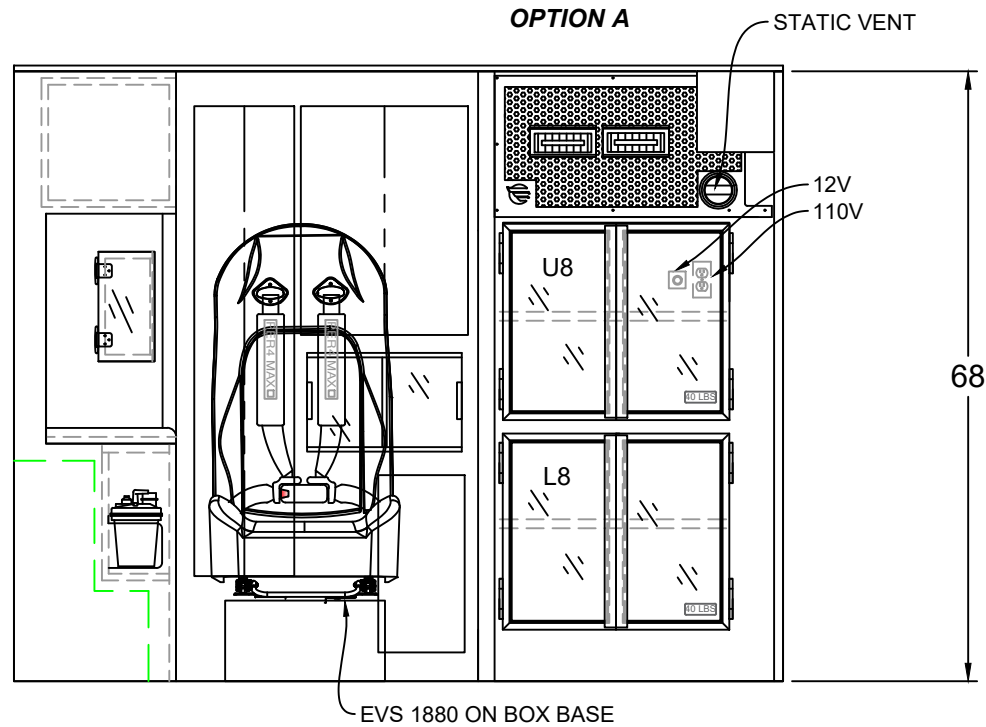

BE ADVISED THAT THESE ARE PRELIMINARY LAYOUTS INTENDED TO ILLUSTRATE DESIGN INTENT AND DIMENSIONS ARE FOR REFERENCE ONLY PRIOR TO FINAL ENGINEERING

<p>CABINET WEIGHT RATINGS:                  RESTOCKING = 30 LBS.                  NON-RESTOCKING = 40 LBS.</p>	INTERIOR CABINET DIMENSIONS IN INCHES								 TYPE 1 CHEVY BULKHEAD INTERIOR
	CABINET	HEIGHT	WIDTH	DEPTH	CABINET	HEIGHT	WIDTH	DEPTH	
	U8	22.50	31.50	19.75					
	L8	22.50	31.50	19.75					
								DATE 2/10/21	SCALE
								DRAWN BY AP	DWG NO 4 / 11

49" AISLE

CA101339

MODEL 1148C

148 x 90 x 68

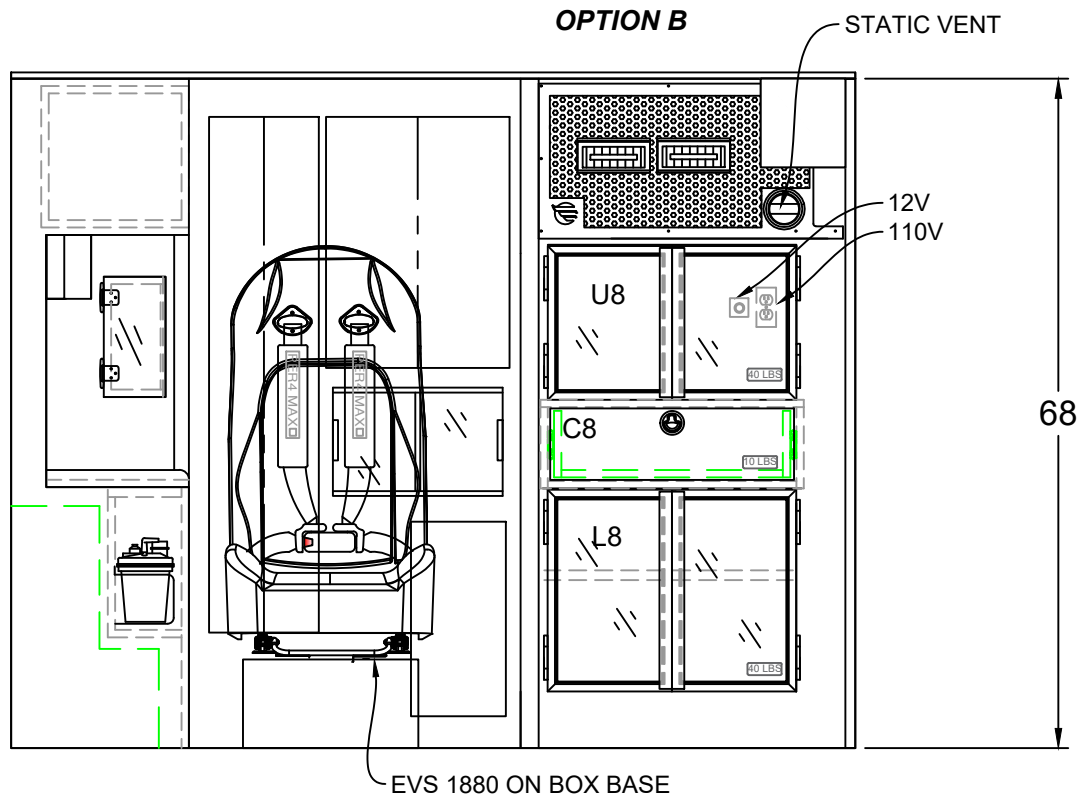

BE ADVISED THAT THESE ARE PRELIMINARY LAYOUTS INTENDED TO ILLUSTRATE DESIGN INTENT AND DIMENSIONS ARE FOR REFERENCE ONLY PRIOR TO FINAL ENGINEERING

<p><u>CABINET WEIGHT RATINGS:</u>                  RESTOCKING = 30 LBS.                  NON-RESTOCKING = 40 LBS.</p>	INTERIOR CABINET DIMENSIONS IN INCHES								 TYPE 1 CHEVY BULKHEAD INTERIOR
	CABINET	HEIGHT	WIDTH	DEPTH	CABINET	HEIGHT	WIDTH	DEPTH	
	U8	15.00	31.50	19.75					
	C8	6.00	22.50	18.25					
	L8	20.50	31.50	19.75					
								DATE 2/10/21	SCALE
								DRAWN BY AP	DWG NO 5 / 11

49" AISLE

CA101339

MODEL 1148C

148 x 90 x 68

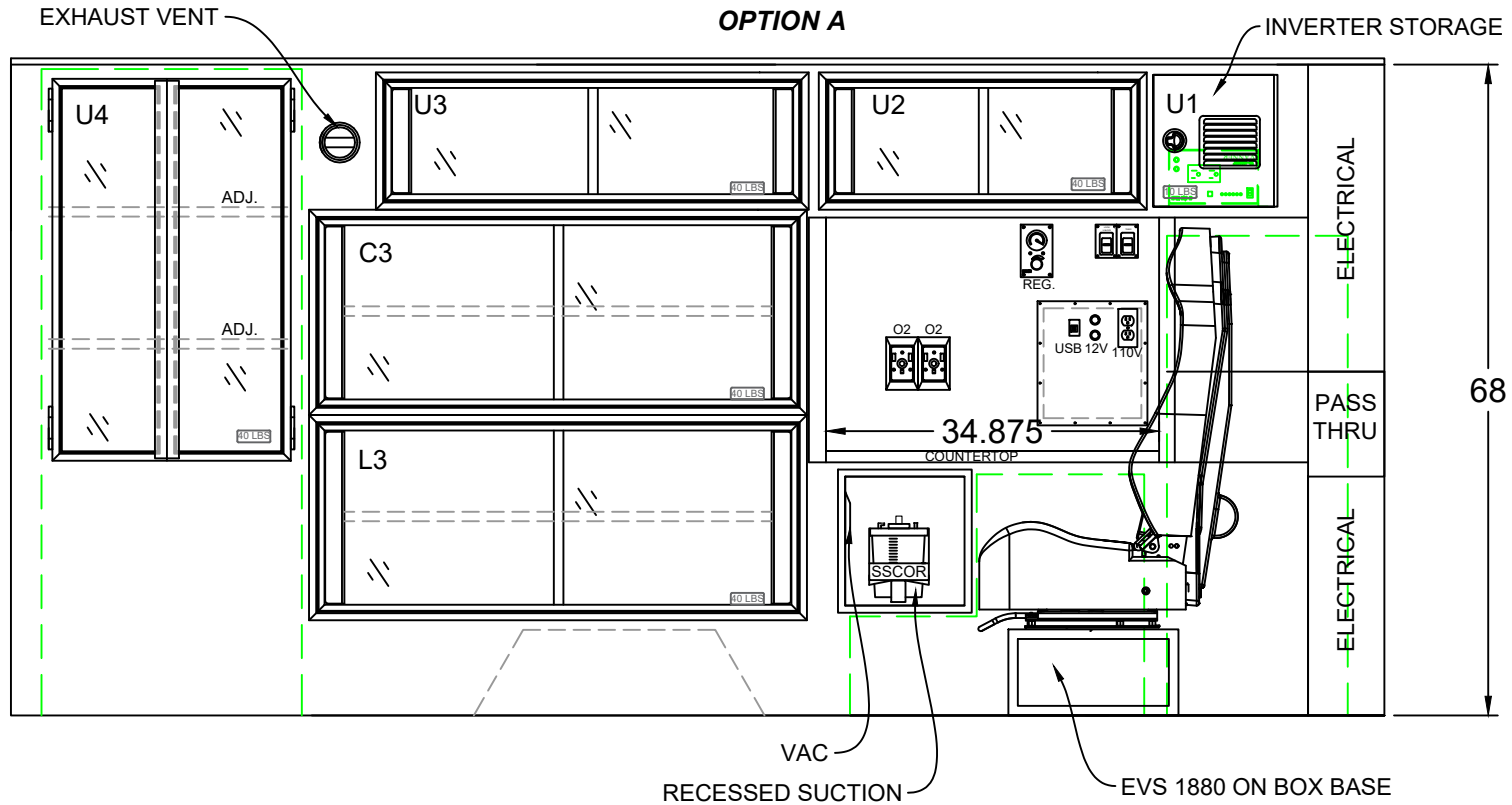

INTERIOR CABINET DIMENSIONS IN INCHES

CABINET	HEIGHT	WIDTH	DEPTH		CABINET	HEIGHT	WIDTH	DEPTH	
U4	40.00	24.75	7.00		L3	20.00	50.50	16.00	
U3	12.75	43.75	16.00						
U2	12.75	32.75	13.75						
U1	13.50	13.00	13.75						
C3	20.00	50.50	16.00						

49" AISLE

**CABINET WEIGHT RATINGS:**  
 RESTOCKING = 30 LBS.  
 NON-RESTOCKING = 40 LBS.

BE ADVISED THAT THESE ARE PRELIMINARY LAYOUTS INTENDED TO ILLUSTRATE DESIGN INTENT AND DIMENSIONS ARE FOR REFERENCE ONLY PRIOR TO FINAL ENGINEERING



TYPE 1 CHEVY

LEFT INTERIOR

DATE:	2/10/21	SCALE:	
DWN BY:	AP	DWG NO:	6 / 11

CA101339

MODEL 1148C

148 x 90 x 68

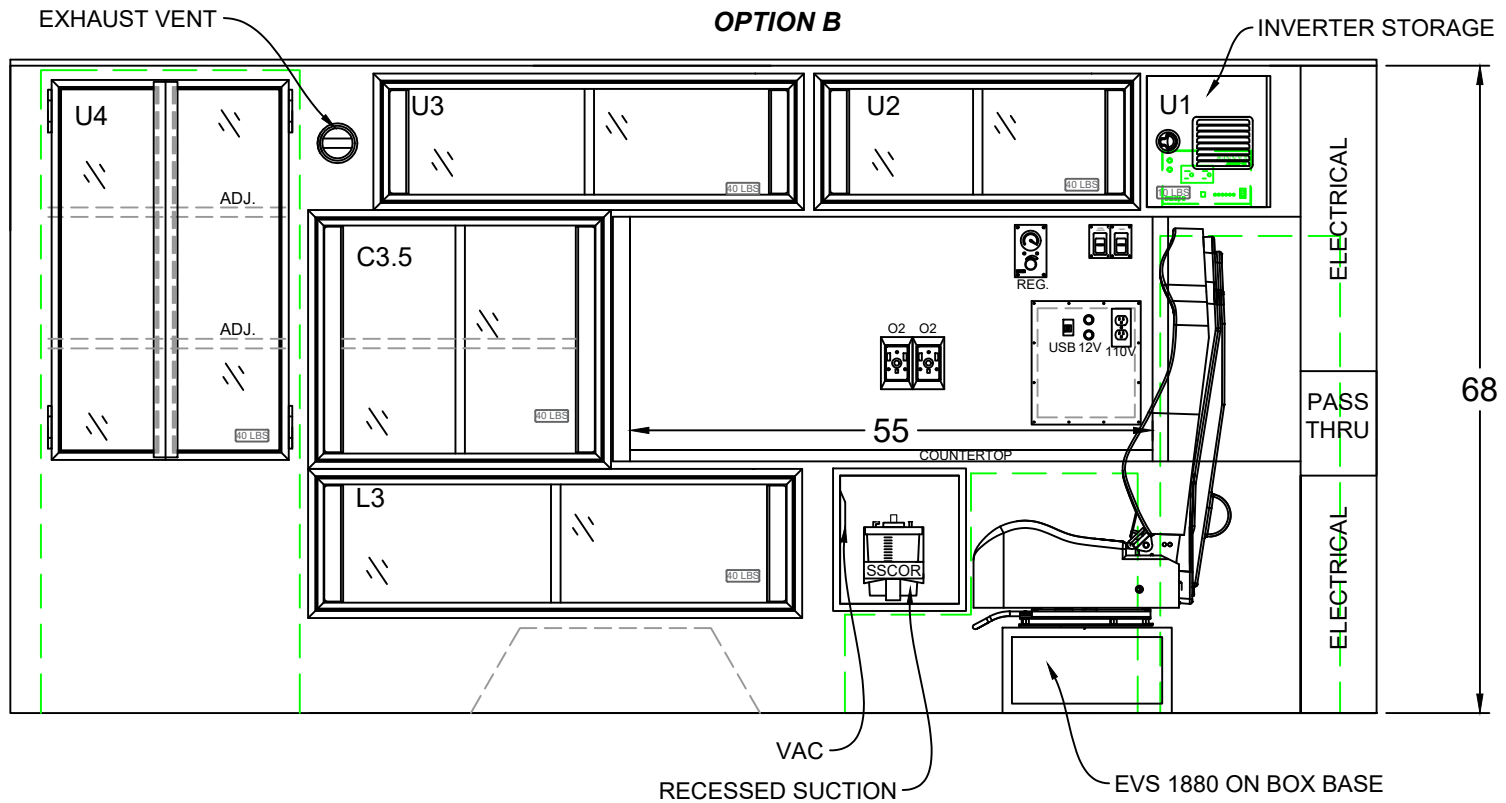

INTERIOR CABINET DIMENSIONS IN INCHES

CABINET	HEIGHT	WIDTH	DEPTH		CABINET	HEIGHT	WIDTH	DEPTH	
U4	40.00	24.75	7.00		L3	14.25	50.50	16.00	
U3	12.75	43.75	16.00						
U2	12.75	32.75	13.75						
U1	13.50	13.00	13.75						
C3.5	25.75	30.25	16.00						

49" AISLE

**CABINET WEIGHT RATINGS:**  
 RESTOCKING = 30 LBS.  
 NON-RESTOCKING = 40 LBS.

BE ADVISED THAT THESE ARE PRELIMINARY LAYOUTS INTENDED TO ILLUSTRATE DESIGN INTENT AND DIMENSIONS ARE FOR REFERENCE ONLY PRIOR TO FINAL ENGINEERING



TYPE 1 CHEVY  
 LEFT INTERIOR

DATE: 2/10/21 SCALE:  
 DWN BY: AP DWG NO: 7 / 11

CA101339

MODEL 1148C

148 x 90 x 68

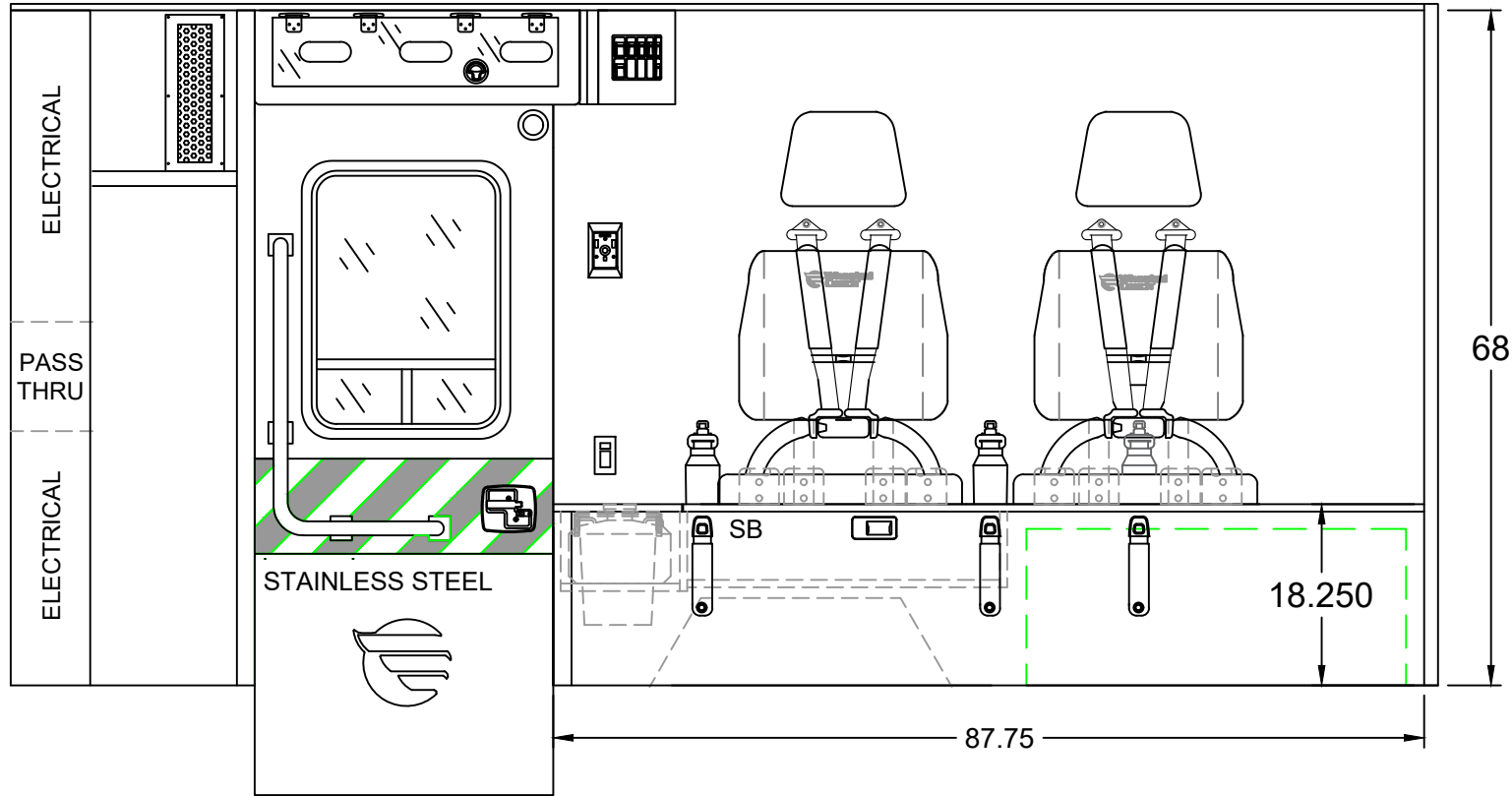

INTERIOR CABINET DIMENSIONS IN INCHES

COMPT.	HEIGHT	WIDTH	DEPTH		COMPT.	HEIGHT	WIDTH	DEPTH	
SB	6.75	30.75	16.00						

49" AISLE

**CABINET WEIGHT RATINGS:**  
 RESTOCKING = 30 LBS.  
 NON-RESTOCKING = 40 LBS.

BE ADVISED THAT THESE ARE PRELIMINARY LAYOUTS INTENDED TO ILLUSTRATE DESIGN INTENT AND DIMENSIONS ARE FOR REFERENCE ONLY PRIOR TO FINAL ENGINEERING



TYPE 1 CHEVY  
 RIGHT INTERIOR

DATE:	2/10/21	SCALE:	
DWN BY:	AP	DWG NO:	8 / 11



CA101339

MODEL 1148C

148 x 90 x 68

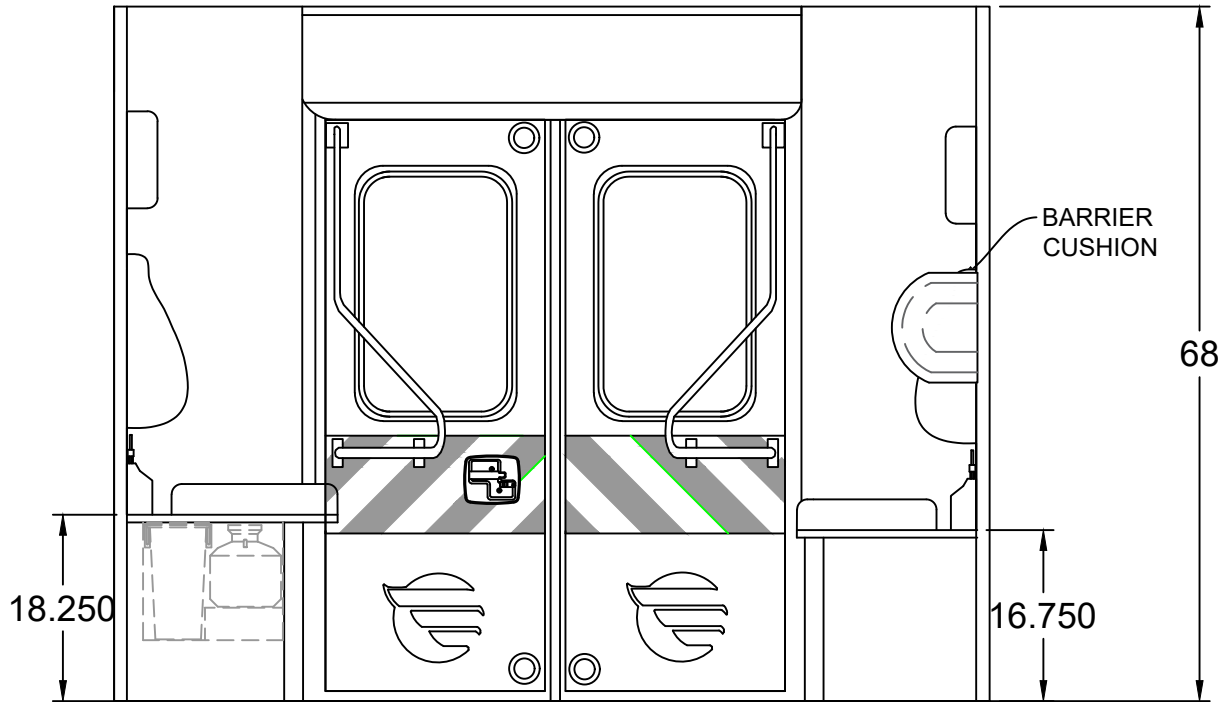

INTERIOR CABINET DIMENSIONS IN INCHES



COMPT.	HEIGHT	WIDTH	DEPTH	COMPT.	HEIGHT	WIDTH	DEPTH

TYPE 1 CHEVY  
REAR BULKHEAD INTERIOR

DATE: 2/10/21 SCALE

49" AISLE

CABINET WEIGHT RATINGS:  
RESTOCKING = 30 LBS.  
NON-RESTOCKING = 40 LBS.

BE ADVISED THAT THESE ARE PRELIMINARY LAYOUTS INTENDED TO ILLUSTRATE DESIGN INTENT AND DIMENSIONS ARE FOR REFERENCE ONLY PRIOR TO FINAL ENGINEERING

DWG NO 9 / 11

AP

CA101339

MODEL 1148C

148 x 90 x 68

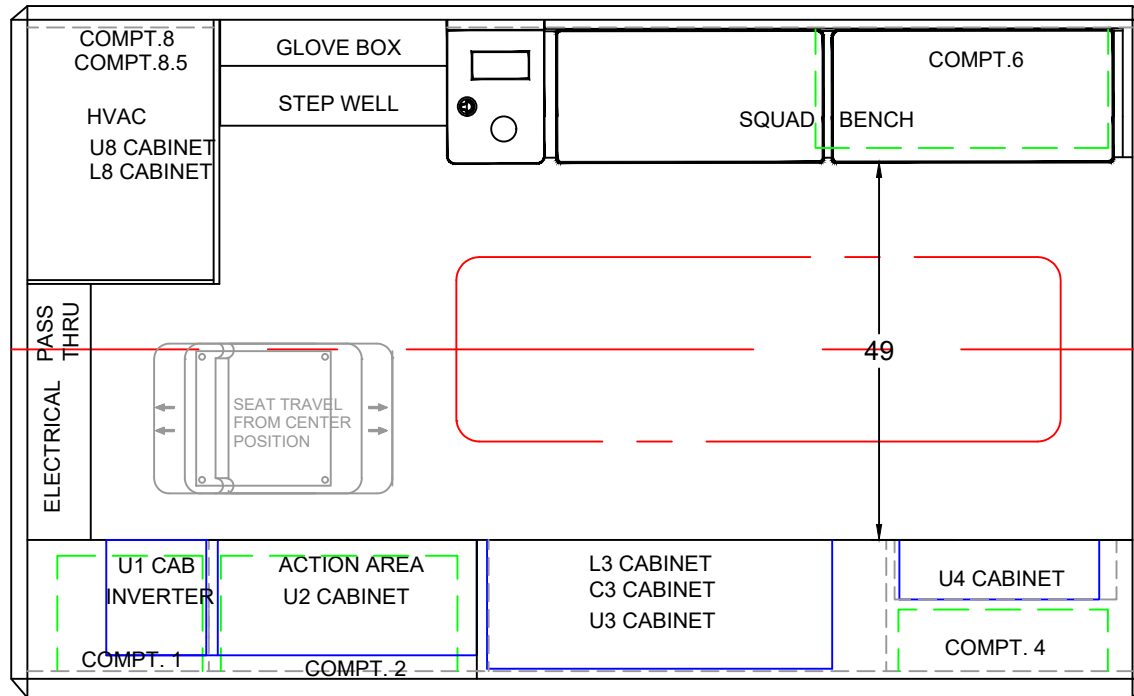

BE ADVISED THAT THESE ARE PRELIMINARY LAYOUTS INTENDED TO ILLUSTRATE DESIGN INTENT AND DIMENSIONS ARE FOR REFERENCE ONLY PRIOR TO FINAL ENGINEERING

INTERIOR CABINET DIMENSIONS IN INCHES

CABINET	HEIGHT	WIDTH	DEPTH	CABINET	HEIGHT	WIDTH	DEPTH



TYPE 1 CHEVY  
FLOOR PLAN

DATE:	2/10/21	SCALE:	
DWN BY:	AP	DWG NO:	10 11

49" AISLE

CA101339

MODEL 1148C

148 x 90 x 68

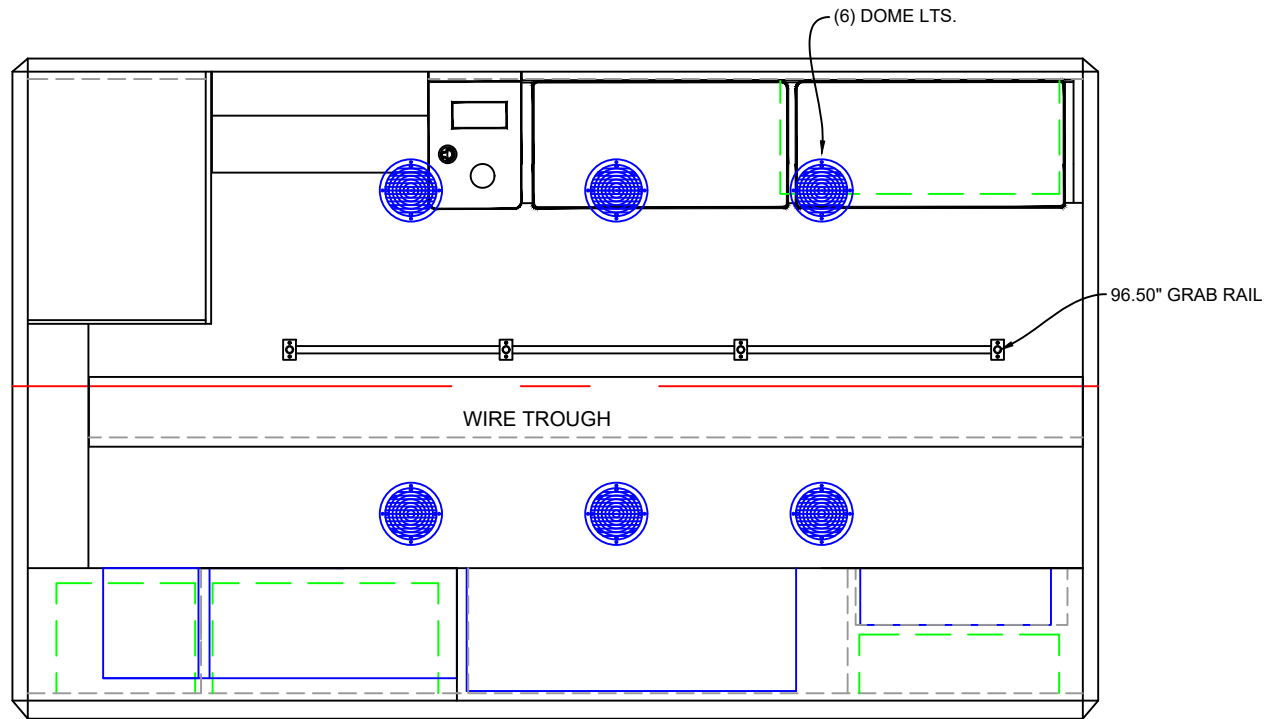

BE ADVISED THAT THESE ARE PRELIMINARY LAYOUTS INTENDED TO ILLUSTRATE DESIGN INTENT AND DIMENSIONS ARE FOR REFERENCE ONLY PRIOR TO FINAL ENGINEERING

	INTERIOR CABINET DIMENSIONS IN INCHES								
	CABINET	HEIGHT	WIDTH	DEPTH	CABINET	HEIGHT	WIDTH	DEPTH	
									TYPE 1 CHEVY LINER
									DATE: 2/10/21 SCALE
									DWG NO
49" AISLE									DWN BY AP 11/11